

Kohler® Diesel Model KD400

1 Cylinder » 401 cc » 7.3 kW/9.8 HP » 3600 RPM » 22.5 ft. lbs. @2100 RPM

Certification

EPA TIER 2
ECE R 24

Features

- 4-Stroke Air-Cooled Diesel Engine
- SEA J609a Crankshaft
- Counter-Clockwise Rotation
- Direct Injection
- Full-Pressure Lubrication with Oil Pump
- Centrifugal Mass Governor
- Built-In Full-Flow Oil Filter
- Oil Breathing Blow-By with Safety Device
- Automatic Extra Fuel Starting Device
- Self-Bleeding Fuel System
- Torque Regulator
- Automatic Compression Release
- Die-Cast Aluminum Crankcase with Integral Cast Iron Cylinder Liner
- Aluminum Cylinder Head
- Mounting Feet
- Hydraulic Valve Lifters

Applications

- Two-Wheel Tractor
- Agricultural Mower
- Agricultural Pump
- High-Pressure Cleaner
- Generator
- Vibrating Plate
- Hydraulic Power Pack
- Vibrating Roller



Kohler® Diesel Model KD400

Specifications

Cylinders	No. of Cylinders	1
Displacement	cc/cu. in.	401/24.5
Bore	mm/in.	82/3.2
Stroke	mm/in.	76/3.0
Compression Ratio		20.3:1
Rating kW/HP	N (80/1269/CEE) ISO 1585	7.3/9.8
	NB ISO 3046 IFN	6.6/8.9
	NA ISO 3046 ICXN	6.2/8.3
Max. Torque	N·m/ft. lbs. @ 2100 RPM	22.5/16.6
Minimum Idling Speed RPM		950-1000
Fuel Tank Capacity	liters/quarts	5/5.3
Oil Consumption	kg/h/lb/h	0.0044/0.0097
Oil Sump Capacity	liters/quarts	1.5/1.6
Min. Allowable Oil Pressure	bar/psi	1-1.5/14.5-21.8
Max. Allowable Angle of Operation (Peak Values)		25° (35°)
Volume of Air Required for Correct Combustion @ 3600 RPM	liters/min/cfm	580/20
Volume of Air Required for Correct Cooling @ 3600 RPM	liters/min/cfm	5500/194
Dry Weight	kg/lbs.	45/99.1
Recommended Battery	V/Ah	12/44
Minimum Pulley Diameters for Belt Drive		

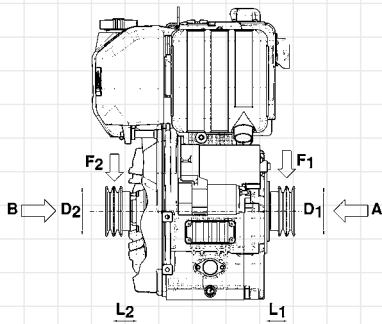

$$D_1 \text{ (mm)} \geq 620 [66 + L_2 \text{ (mm)}] \frac{N \text{ (kW)}}{n \text{ (RPM)}}$$

$$D_2 \text{ (mm)} \geq 650 [53 + L_1 \text{ (mm)}] \frac{N \text{ (kW)}}{n \text{ (RPM)}}$$

Max. allowable axial load in both directions A-B = 200 kg/441 lb_f

Sound Pressure Level dB (A)

Sound Pressure Level Polar Diagram
Open Field at 7 Meters - No Load
Running Engine.

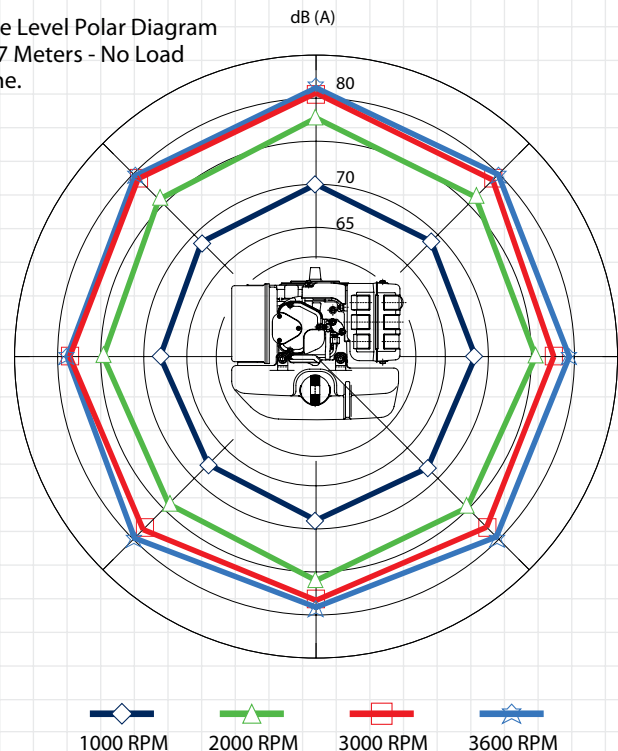

Kohler® Diesel Model KD400

Curves

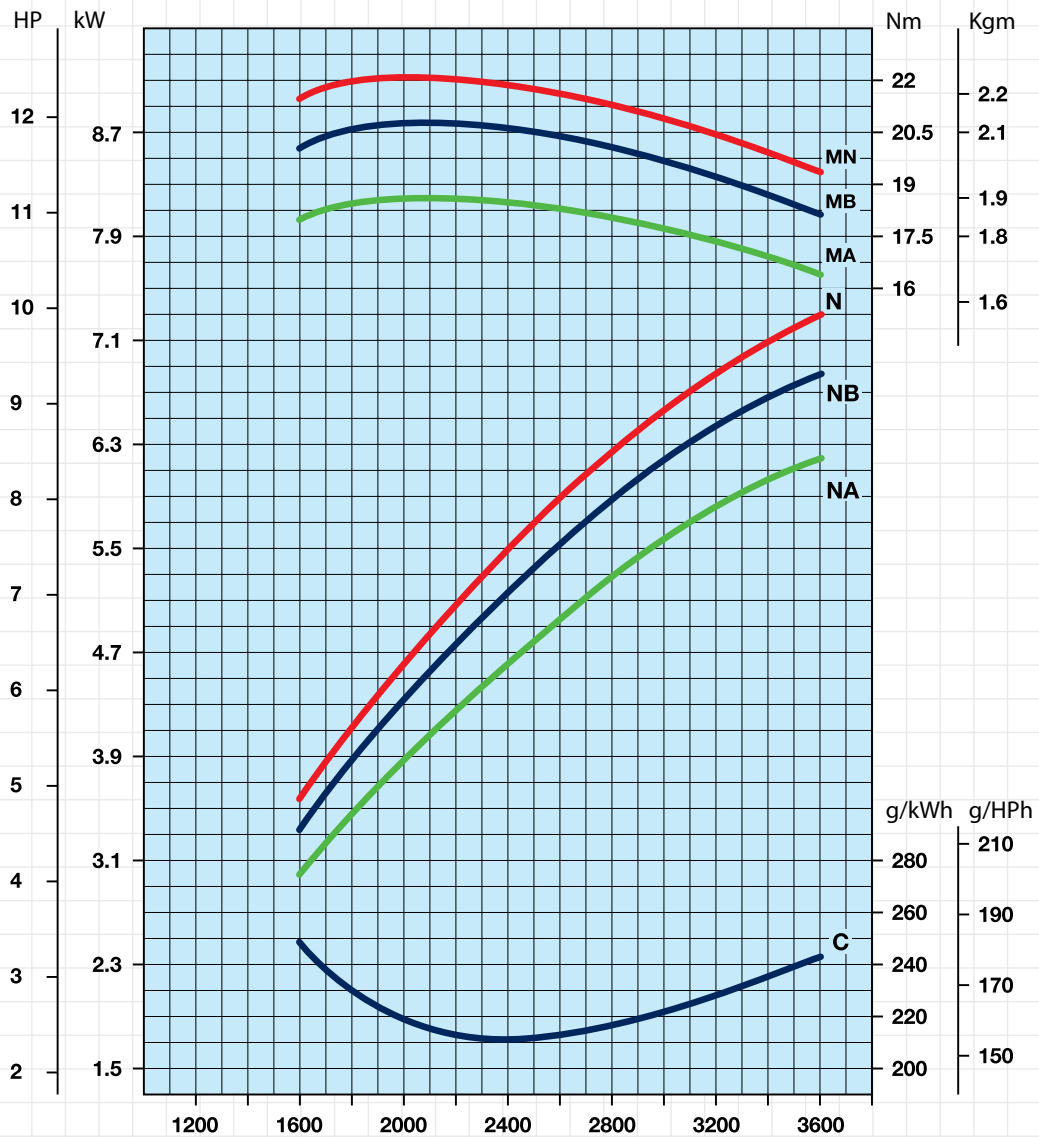

- N Power curve - 80/1269/CEE - ISO 1585 -
- NB Power curve - ISO 3046/1 - IFN -
- NA Power curve - ISO 3046/1 - ICXN -
- MN Torque curve - (N curve)
- MB (B curve - MA (A curve)
- C Specific fuel consumption - (NB curve)

Kohler® Diesel Model KD400

Technical Drawings

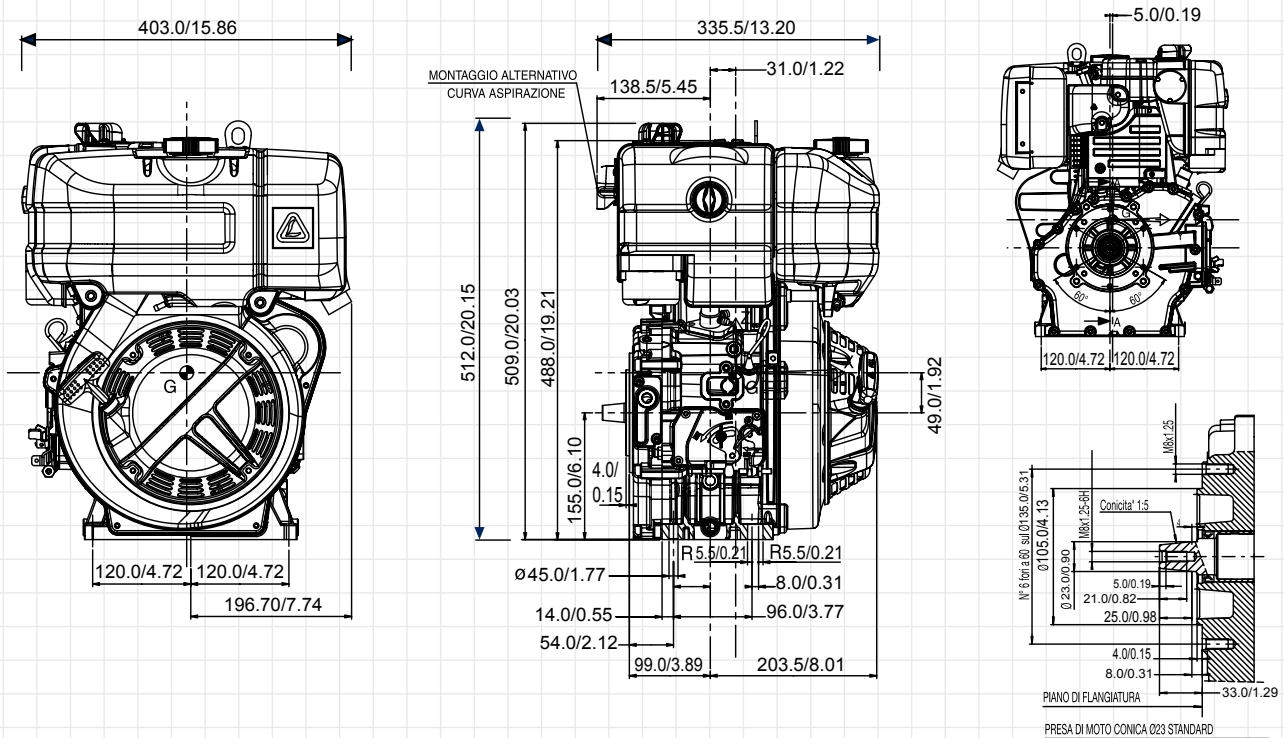

Standard Equipment

- Recoil Start with Automatic Compression Release
- Fuel Tank
- Fuel Filter
- Dry Air Cleaner
- Muffler with Guard
- Accelerator and Stop Manual Control
- 12 V Electric Start with Control Panel
- SAE J609a Ext 4 Crankshaft with Type B Mtg. Flange
- Fuel Safety Shutdown for Low Oil Pressure

Accessories

- Internal Dynamic Balancer
- 24 V Electric Start
- Accelerator and Stop Remote Control
- Key Start Panel with Shutdown Device
- Fuel Lift Pump
- Oil Temperature Switch
- Glow Plug on Intake Manifold
- SAE J609a Ext 9, 6, and 3 Integral Crankshafts with Type B Mtg. Flange
- Extended Wiring Harness